

The petainerKeg Hybrid format can be filled on many suitably modified steel Keg-Fillers.  
Please contact the filling machine supplier for advice, format parts and program modifications.

When using the petainerKeg Hybrid format, please note the following:

## General

Modify the machine program in accordance with the instructions below:

1. All steel Keg washing and sterilising functions need to be inhibited, including the “head seal check” and the spear adapter moving, except on the filling head.
2. Keg must be filled volumetrically to the required capacity to provide head space.

## Racker Conversion

1. Check that the filling head spear adaptor (piston top) dimensions comply with the Petainer closure drawing. Failure to do so may damage the closure and prevent its proper operation!
2. Maximum allowed top load is:  
20 l Hybrid: 2000 N (450 lbf) with 0,5bar / 7,25 psi in the keg.

## Filling

1. We recommend disinfecting the fitting surface before filling (e.g. with 70% alcohol).
2. Purge/rinse the Keg with CO<sub>2</sub> (or other appropriate inert gas) to remove air from the Keg prior to filling.
3. **By request** we deliver the Hybrid with >99% N<sub>2</sub> inside.
4. Keg counter-pressure and filling (maximum pressure 3,1 bar / 45 psi) can then proceed as normal.

## Intermediate head rinsing

If the racker design allows, it is desirable to flush/disinfect the filling head and each keg valve from outside before and after filling.

1. e.g. with hot water (1 second with 85°C / 185 F).
2. Water pressure before filling maximum 1,0 bar / 14 psi.
3. Water pressure after filling should not exceed the pressure in the Keg.

## Safety

1. All machinery must be guarded in accordance with local regulations.
2. Eye and ear protection, together with work-wear should be used.
3. PET Kegs can get damaged by sharp objects.
4. Under filled Kegs or other rejects should be de-pressurised prior to disposal, using the Pressure Release Tool (PRT) supplied.



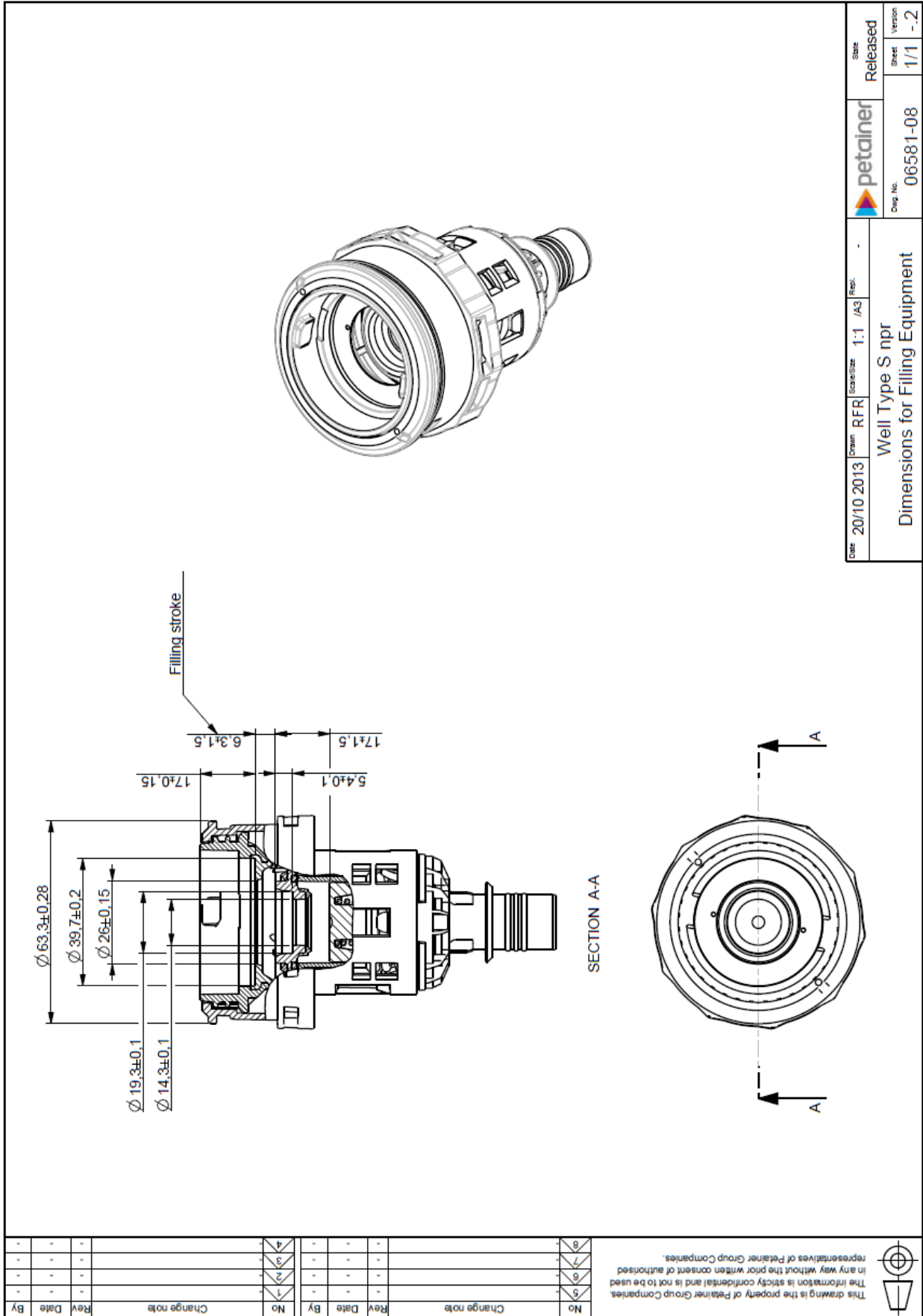

Date	20/10 2013	Drawn	RFR	Scale	1:1	Size	A3	Rev.	-
Well Type S npr Dimensions for Filling Equipment									
petainer								Dwg No.	06581-08
Released								Sheet	1/1
Released								Version	-2

This drawing is the property of Petainer Group Companies. In any way without the prior written consent of authorised representatives of Petainer Group Companies.



# Keg-Filler Set-up Hybrid S npr

S npr = S-type without automatic pressure relief function

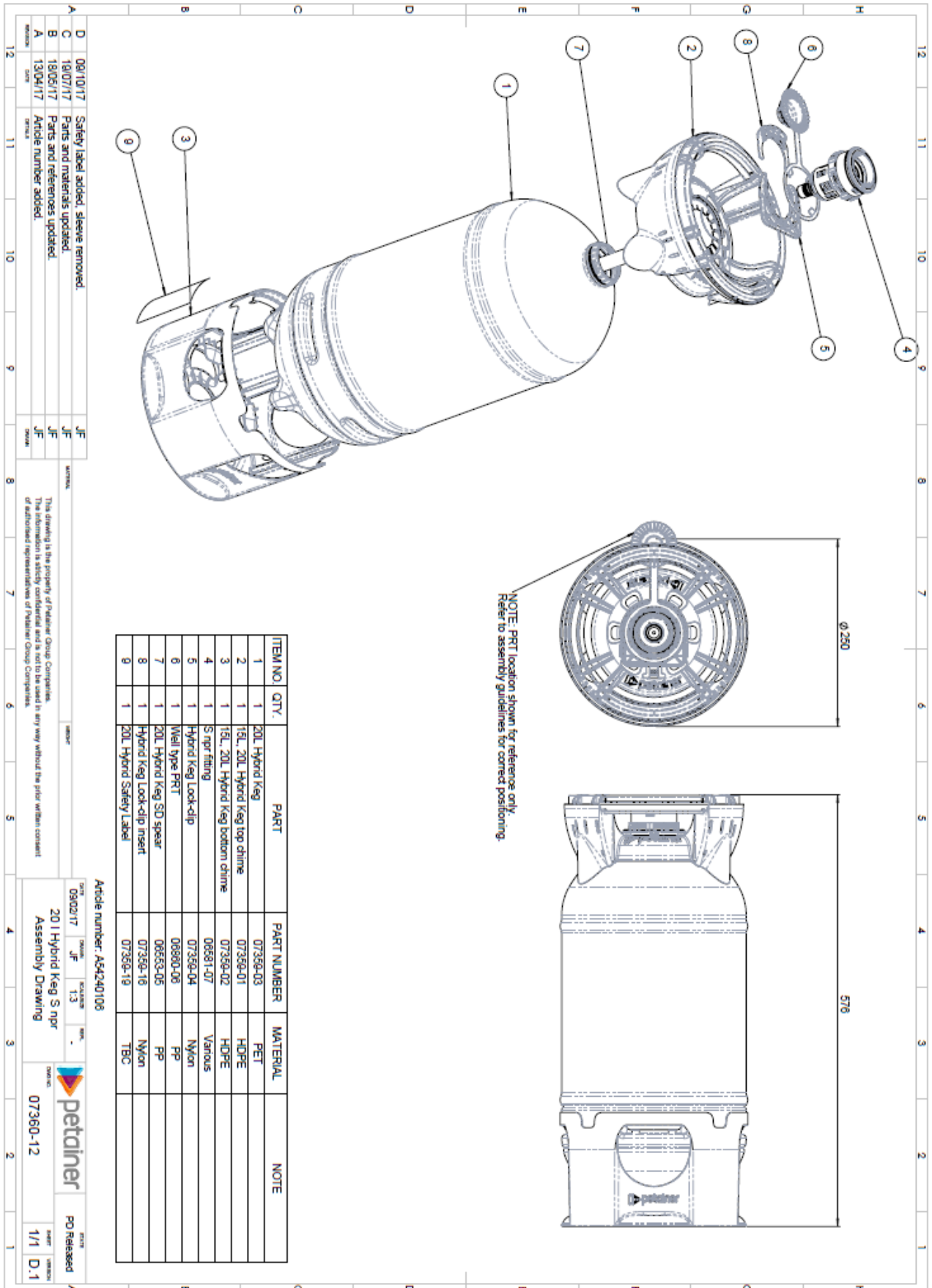

ITEM NO.	QTY.	PART	PART NUMBER	MATERIAL	NOTE
1	1	ZOL Hybrid Keg	07359-03	PET	
2	1	15L, ZOL Hybrid Keg top drive	07359-01	HDPE	
3	1	15L, ZOL Hybrid Keg bottom drive	07359-02	HDPE	
4	1	S npr fitting	08881-07	Various	
5	1	Hybrid Keg Look-clip	07359-04	Nylon	
6	1	Well type PRT	08880-06	PP	
7	1	ZOL Hybrid Keg SD spear	08883-05	PP	
8	1	Hybrid Keg Look-clip insert	07359-16	Nylon	
9	1	ZOL Hybrid Safety Label	07359-19	TBC	

REV.	DATE	DESCRIPTION	BY	CHKD.
D	08/10/17	Safety label added, sleeve removed.	JF	JF
C	18/07/17	Parts and materials updated.	JF	JF
B	18/05/17	Parts and references updated.	JF	JF
A	13/04/17	Article number added.	JF	JF

Article number: A64240108

09/02/17 1.3 petainer PO Released 1/1 D.1

This drawing is the property of Petainer Group Companies. The information is strictly confidential and is not to be used in any way without the prior written consent of authorized representatives of Petainer Group Companies.